

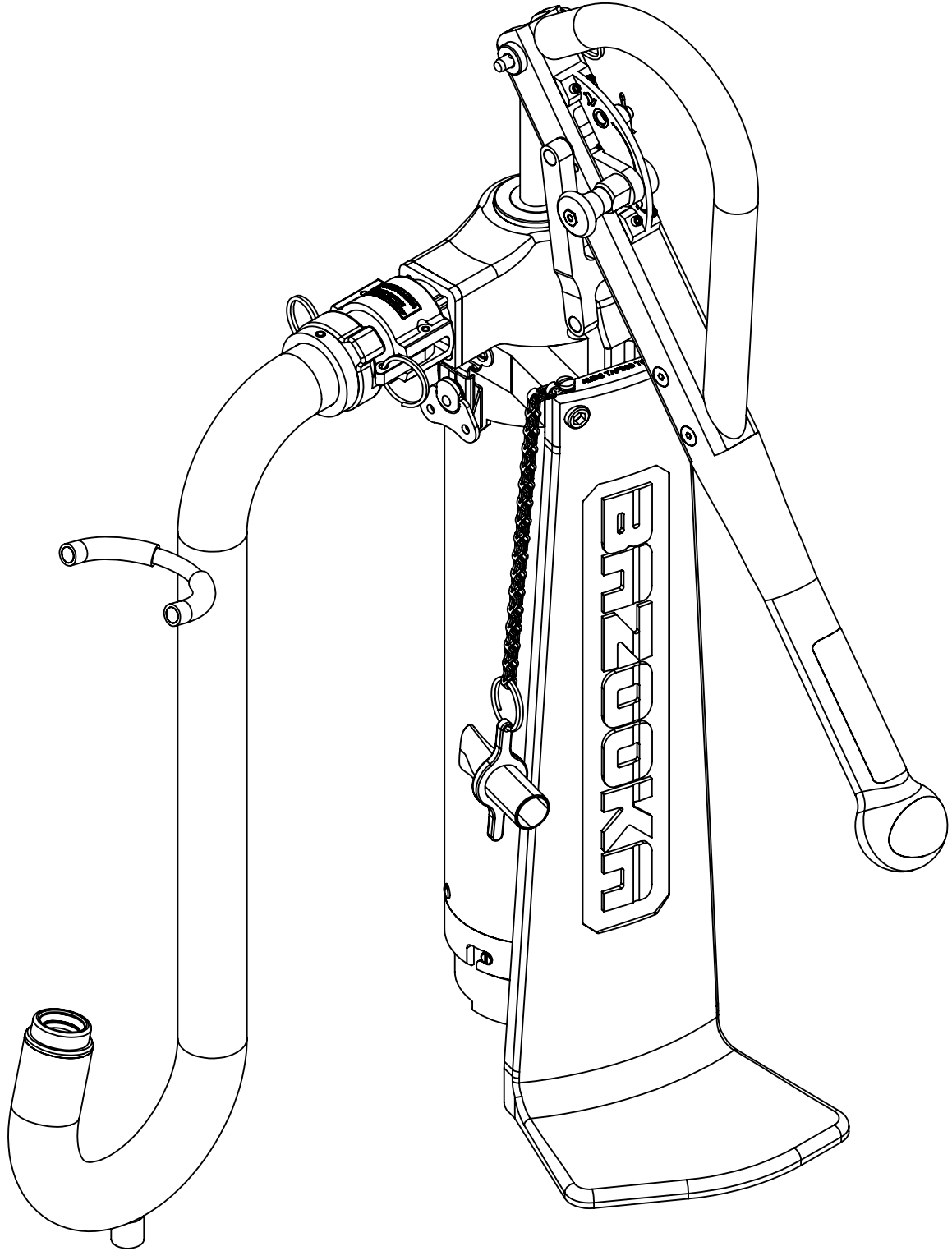

REVISIONS				
ECN	REV.	DESCRIPTION	DATE	BY
	1	COPIED FROM AMES	01/10	MWJ

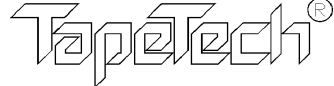

	BY	DATE
DRAWN	MWJ	01/10
CHECKED	X.X.X.	##/##
ALL DIMENSIONS IN INCHES UNLESS OTHERWISE NOTED		
TOLERANCES UNLESS NOTED		
.XX ± 0.010"	ANGULAR ±.5°	
.XXX ± 0.005"		
MATERIAL: N/A		

Bazooka Pump			
			
SIZE B	SCALE = 1:4	DWG. NO. 790000	REV. 1
ASSEMBLY REF. NO. N/A			SHEET 1 of 6

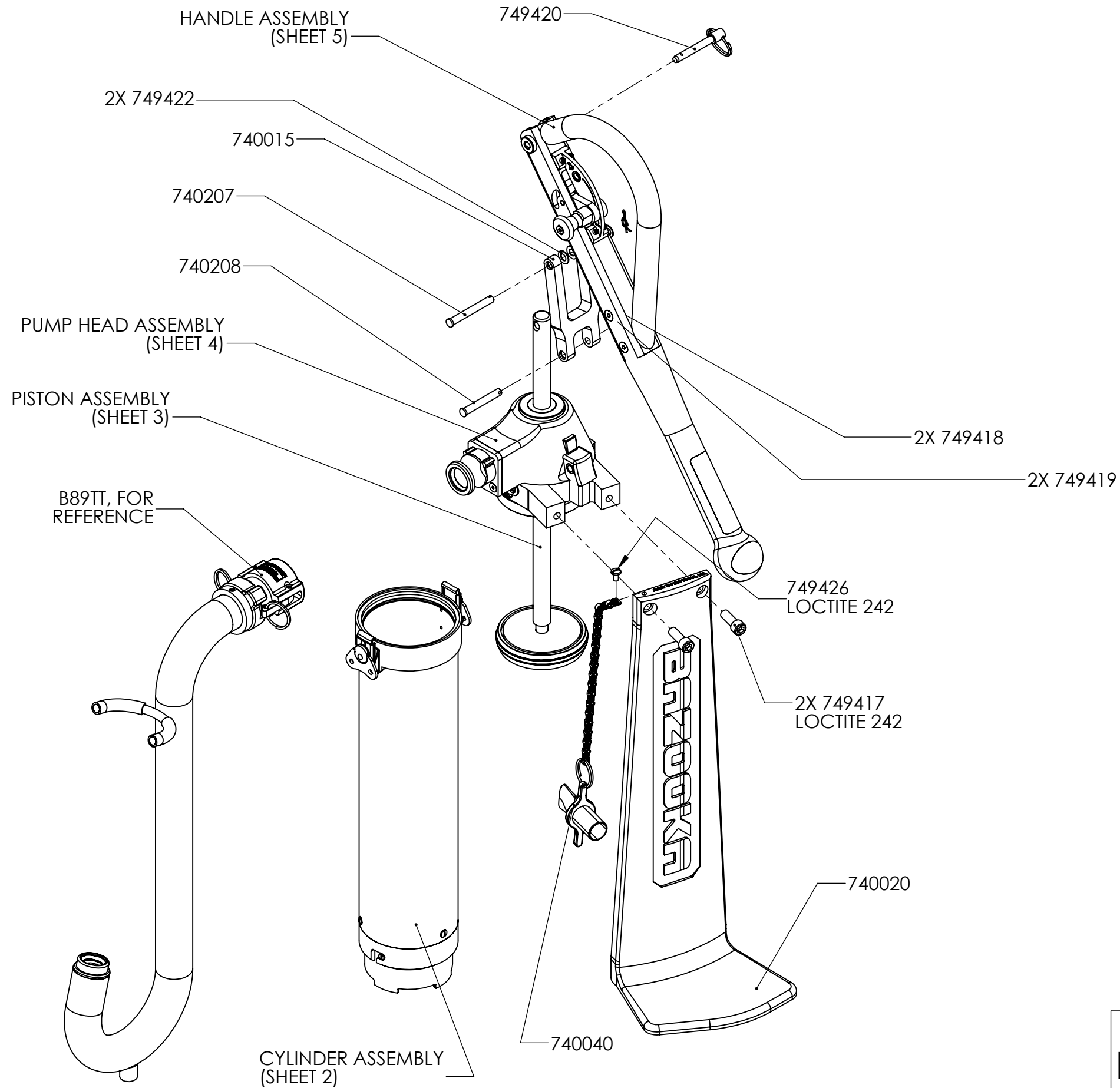

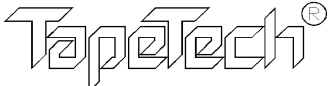
B79TT	Bazooka Pump	
	 an <i>Axia</i> Enterprise	REV. 1

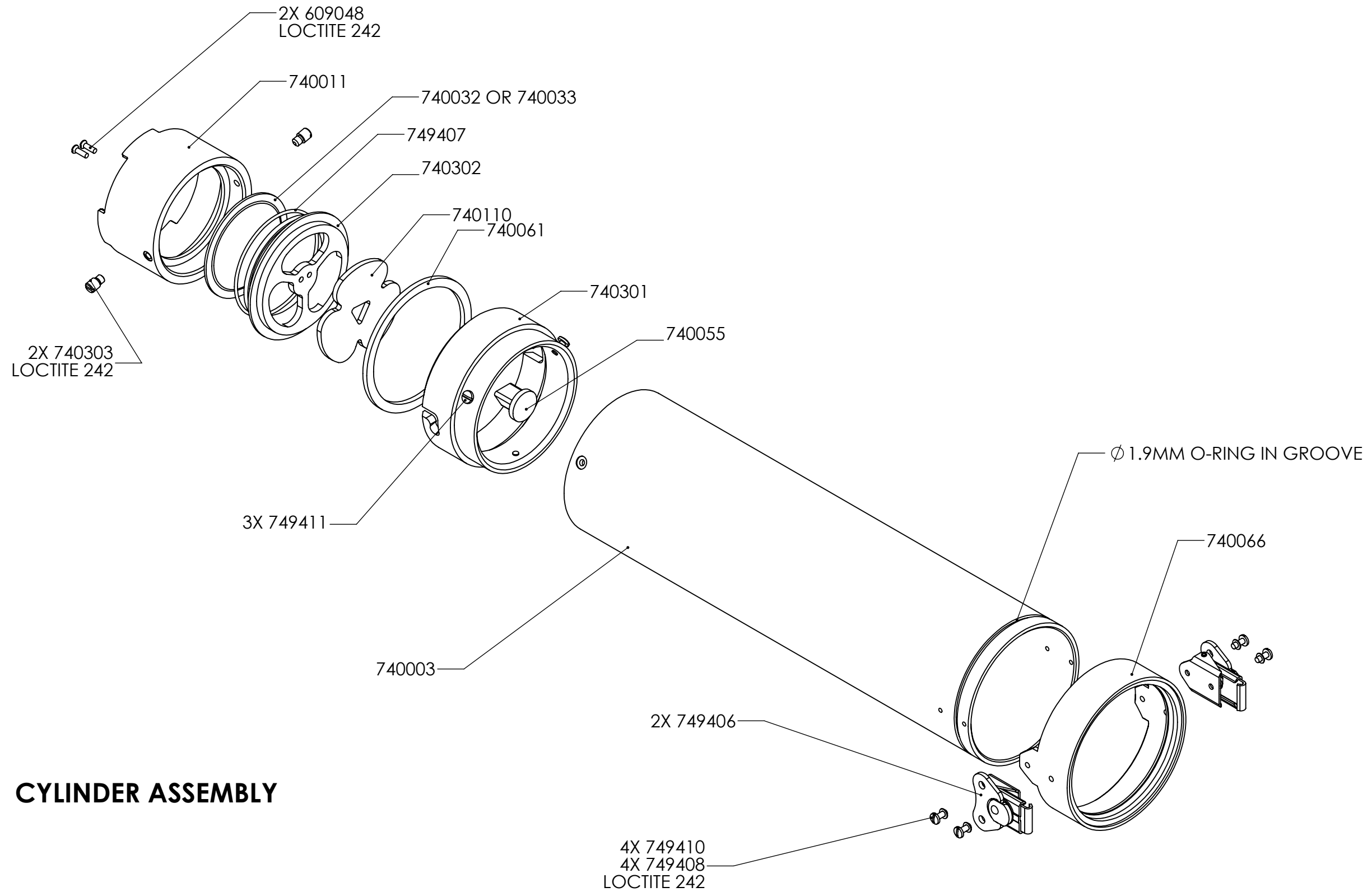

**CYLINDER ASSEMBLY**

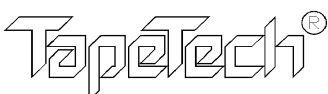
B79TT	Bazooka Pump	
	 an <i>Axia</i> Enterprise	REV. 1

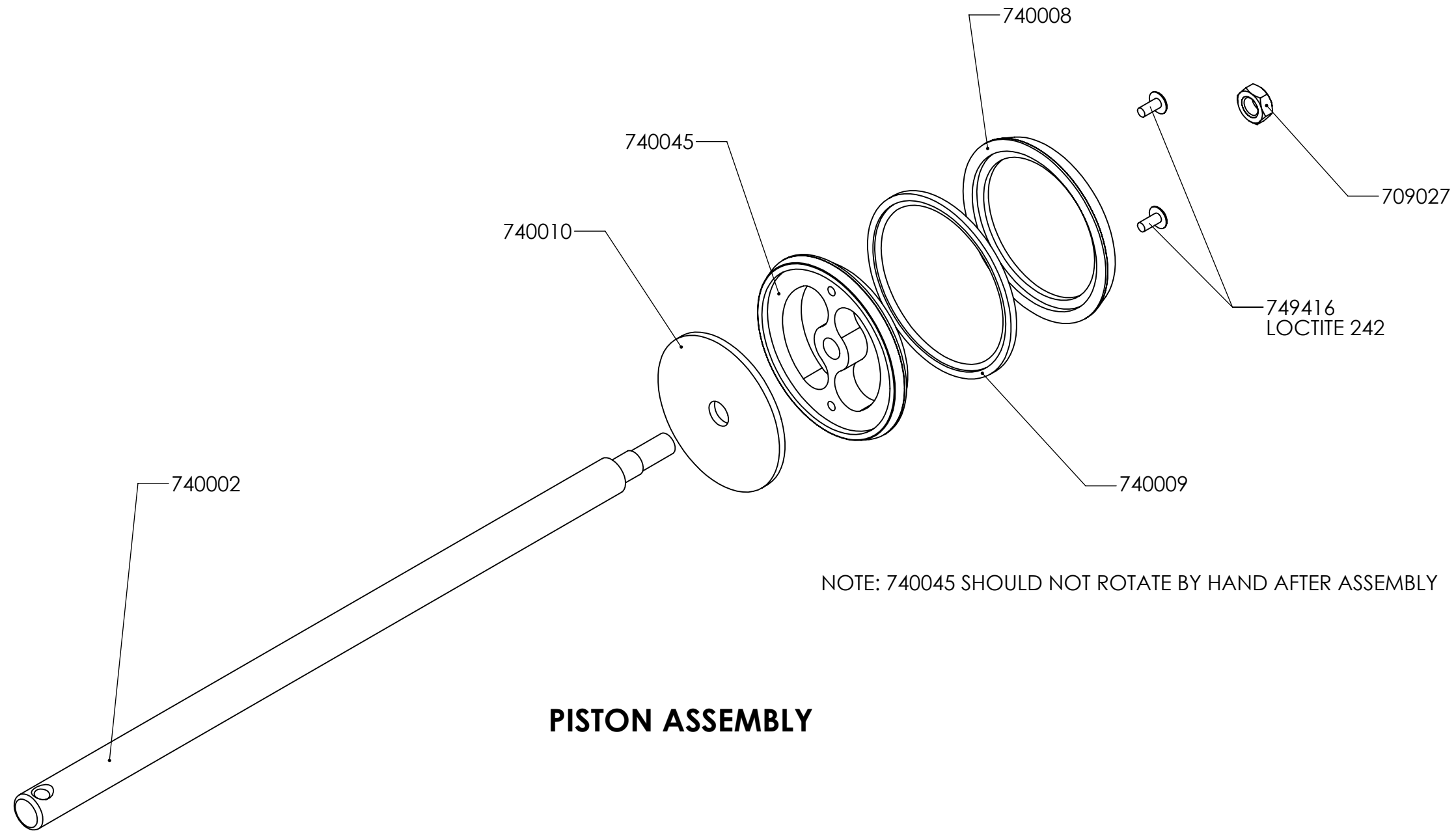

**PISTON ASSEMBLY**

B79TT	Bazooka Pump	
	 an <i>Axia</i> Enterprise	REV. 1

# PUMP HEAD ASSEMBLY

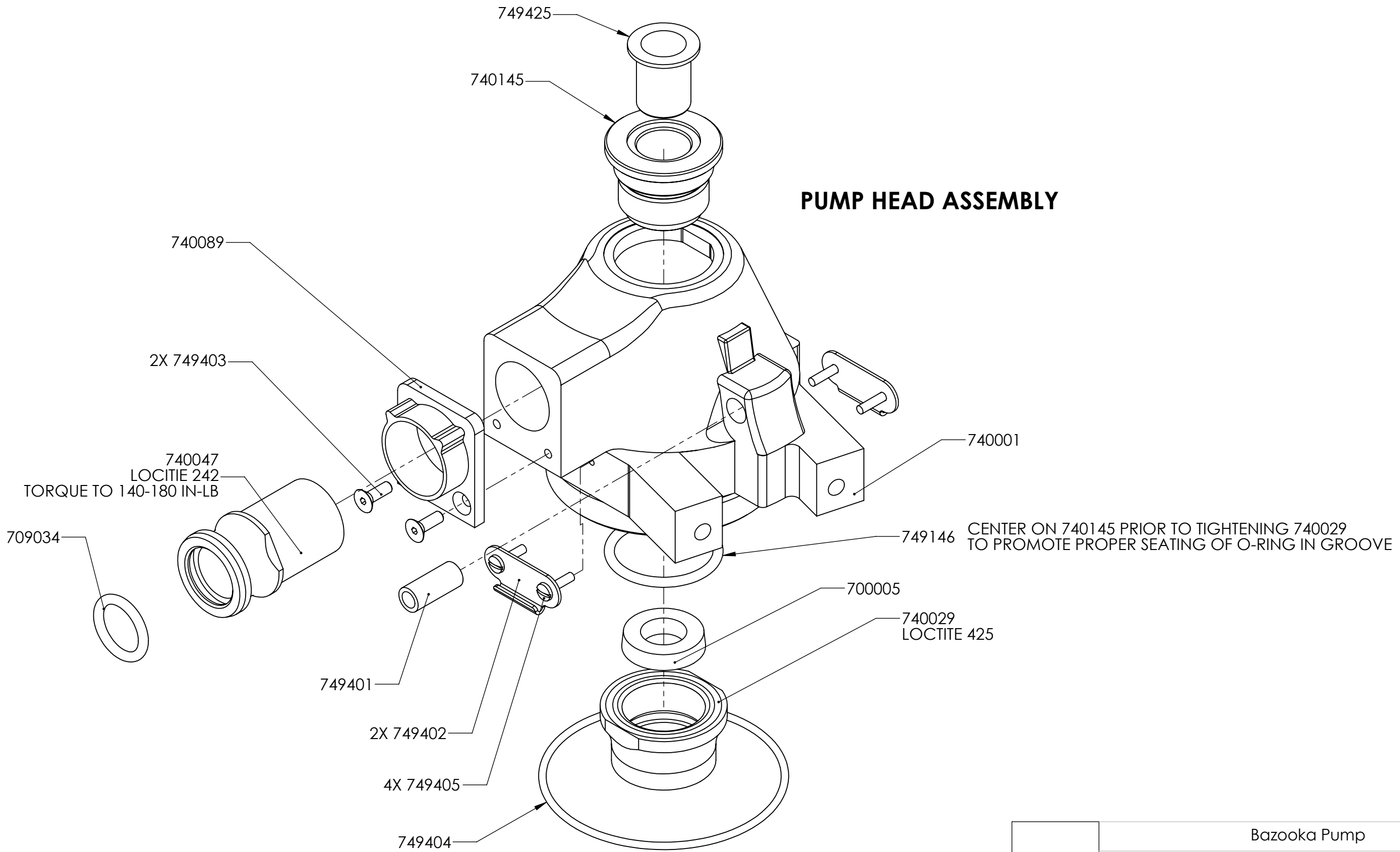

B79TT	Bazooka Pump	
	 an <i>Axia</i> Enterprise	REV. 1

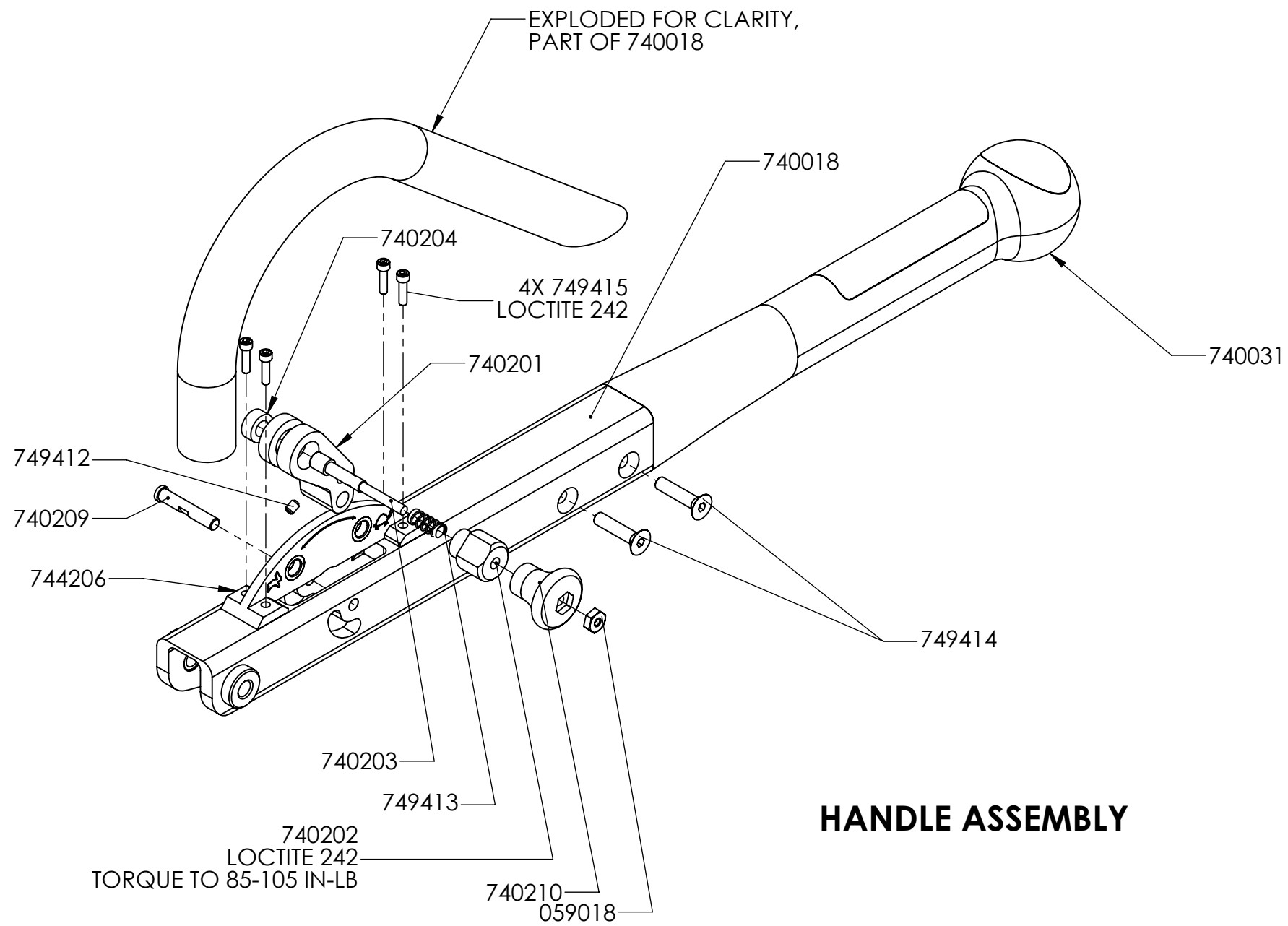

B79TT	Bazooka Pump	
	 an <i>Axia</i> Enterprise	REV. 1